

SCHNITT F-F

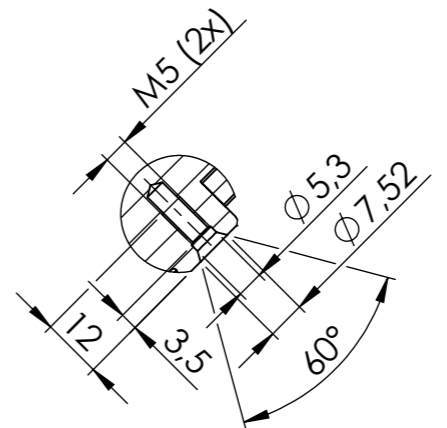
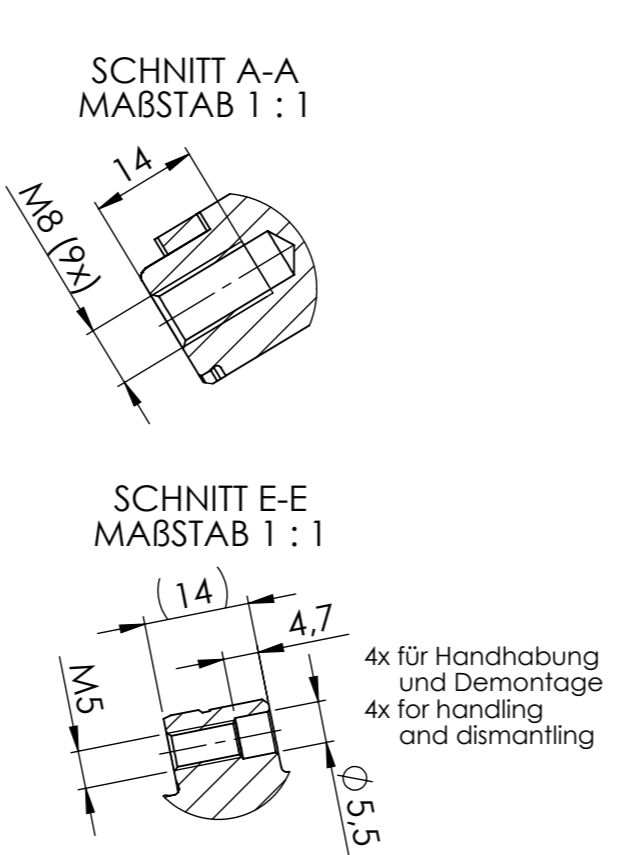
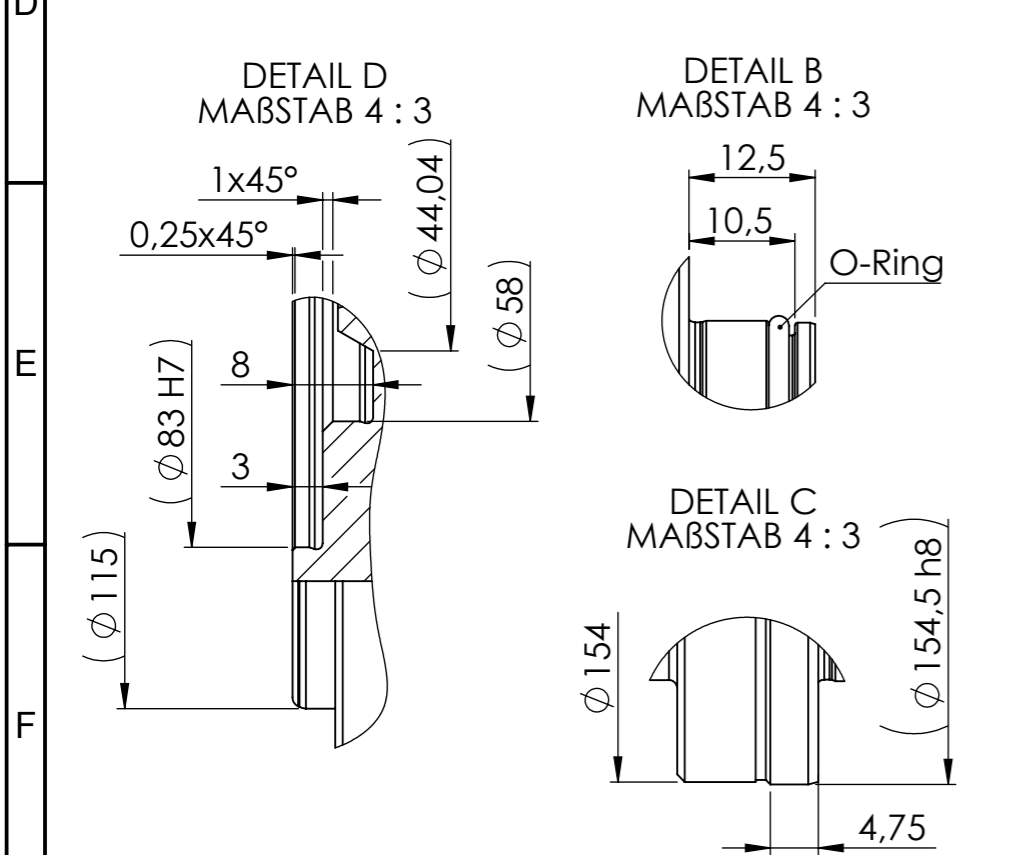

| | | | | | | | | | |
|---------------------------------|---------------|---------|------------|-------|------|----------------------------|-----------|-----------|-------|
| Idx | Änderungs-Nr. | Datum | Name | Datum | Name | Maßstab | Teile-Nr. | | |
| | | gez. | 27.02.2020 | AU | | Scale | 2:3 | Part. No. | |
| | | gepr. | 27.02.2020 | FK | | Werkstoff | | Material | Masse |
| | | Konstr. | 27.02.2020 | FK | | Halbzeug | | | Mass |
| | | Prod.T. | 27.02.2020 | | | Rohteil-Nr. | | | |
| | | Qual.S. | 27.02.2020 | | | Benennung | Title | | |
| | | Mont. | 27.02.2020 | | | PSC030-V-E-XXX-X-XX-F-0 | | | |
| | | | | | | Einbausatz Vollwelle - KS3 | | | |
| Oberfläche-Surface DIN ISO 1302 | | | | | | Zeichnungs-Nr. | | | |
| Allgemeintoleranzen | | | | | | Drwg.No. | | | |
| General Tolerances | | | | | | C0030-006-3A01 | | | |
| Werkstückkanten DIN6784 | | | | | | Blatt-Page | | | |
| Edges of working parts | | | | | | 1 / 1 | | | |
| Datei | | | | | | Ers.f. | | Ers.d. | |
| File | | | | | | Repl. | | Repl. by | |
| 030V-KS3-SM-01 | | | | | | | | | |

Schutzvermerk nach DIN ISO 16016 beachten. Copyright reserved.