

DETAIL D
MAßSTAB 1 : 1

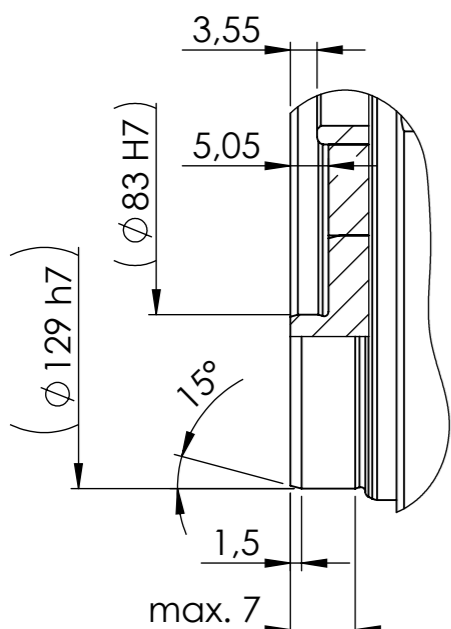

DETAIL B
MAßSTAB 1 : 1

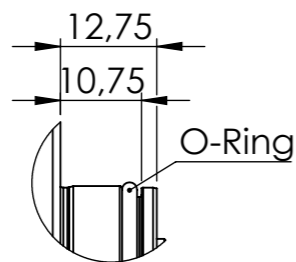

DETAIL C
MAßSTAB 1 : 1

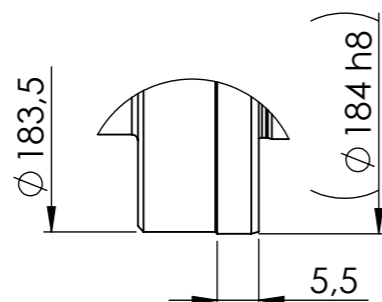

SCHNITT A-A
MAßSTAB 1 : 1

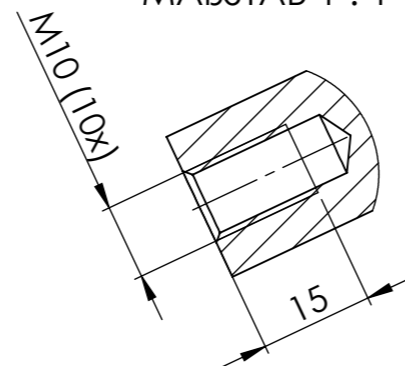

SCHNITT E-E
MAßSTAB 1 : 1

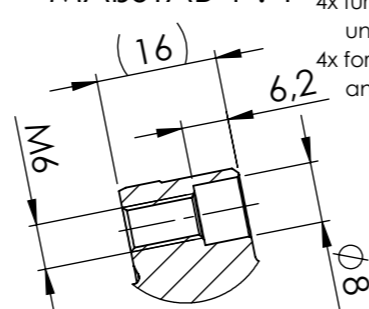

4x für Handhabung
und Demontage
4x for handling
and dismating

SCHNITT F-F
MAßSTAB 1 : 1

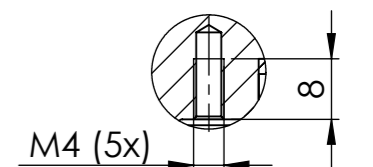

5x für Schutzhülse
5x for protection sleeve

Idx	Änderungs-Nr.	Datum	Name	Datum	Name	Maßstab Scale	Teile-Nr. Part. No.	Material	Masse Mass	Title
		gez.	28.02.2020	AU		1:2				
		gepr.	28.02.2020	FK		Werkstoff				
		Konstr.	28.02.2020	FK		Halbzeug				
		Prod.T.	28.02.2020			Rohteil-Nr.				
		Qual.S.	28.02.2020			Benennung				
		Mont.	28.02.2020							
				C A D		PSC057-H-E-XXX-X-XX-F-0		Title		
				Oberfläche-Surface DIN ISO 1302		Einbausatz Hohlwelle - KS3				
				Allgemeintoleranzen General Tolerances		Zeichnungs-Nr.		Drwg.No.		Blatt-Page
				Werkstückkanten DIN6784 Edges of working parts		C0057-021-3A01				1 / 1
				Datei File		057H-KS3-SM-01		Ers.f. Repl.		Ers.d. Repl. by