

SCHNITT B-B
MAßSTAB 1 : 2

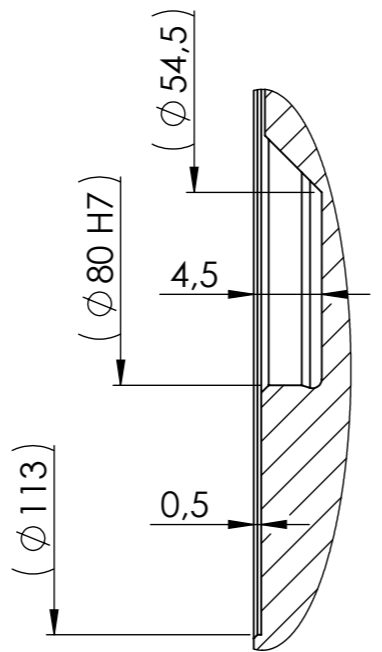

DETAIL A
MAßSTAB 2 : 1

Varianten Variants PSC080V	
Nennübersetzung Nominal ratio	exakte Übersetzung Exact ratio
50	754/15
63	33176/525
80	57304/735
100	1508/15
125	12818/105
160	1508/9
200	107068/525

Idx	Änderungs-Nr.	Datum	Name	Datum	Name	Maßstab Scale	2:5	Teile-Nr. Part. No.		
		gez.	23.01.2020	AU		Werkstoff		Material	Masse	
		gepr.	23.01.2020			Halbezeug			Mass	
		Konstr.	23.01.2020	AU		Rohteil-Nr.				
		Prod.T.	23.01.2020			Benennung			Title	
		Qual.S.	23.01.2020			PSC080-H-B-XXX-2-XX-F-0				
		Mont.	23.01.2020				Zeichnungs-Nr.	Drwg.No.	Blatt-Page	
Oberfläche-Surface DIN ISO 1302 Allgemeintoleranzen General Tolerances						 melior motion Passion for precision.				
Werkstückkanten DIN6784 Edges of working parts							Datei File	PSC080-V-B-XXX-2-XX-F-0	Ers.f. Repl.	Ers.d. Repl. by