

SCHNITT A-A
MAßSTAB 1 : 2

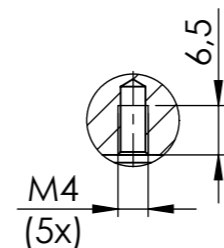

SCHNITT B-B
MAßSTAB 1 : 1

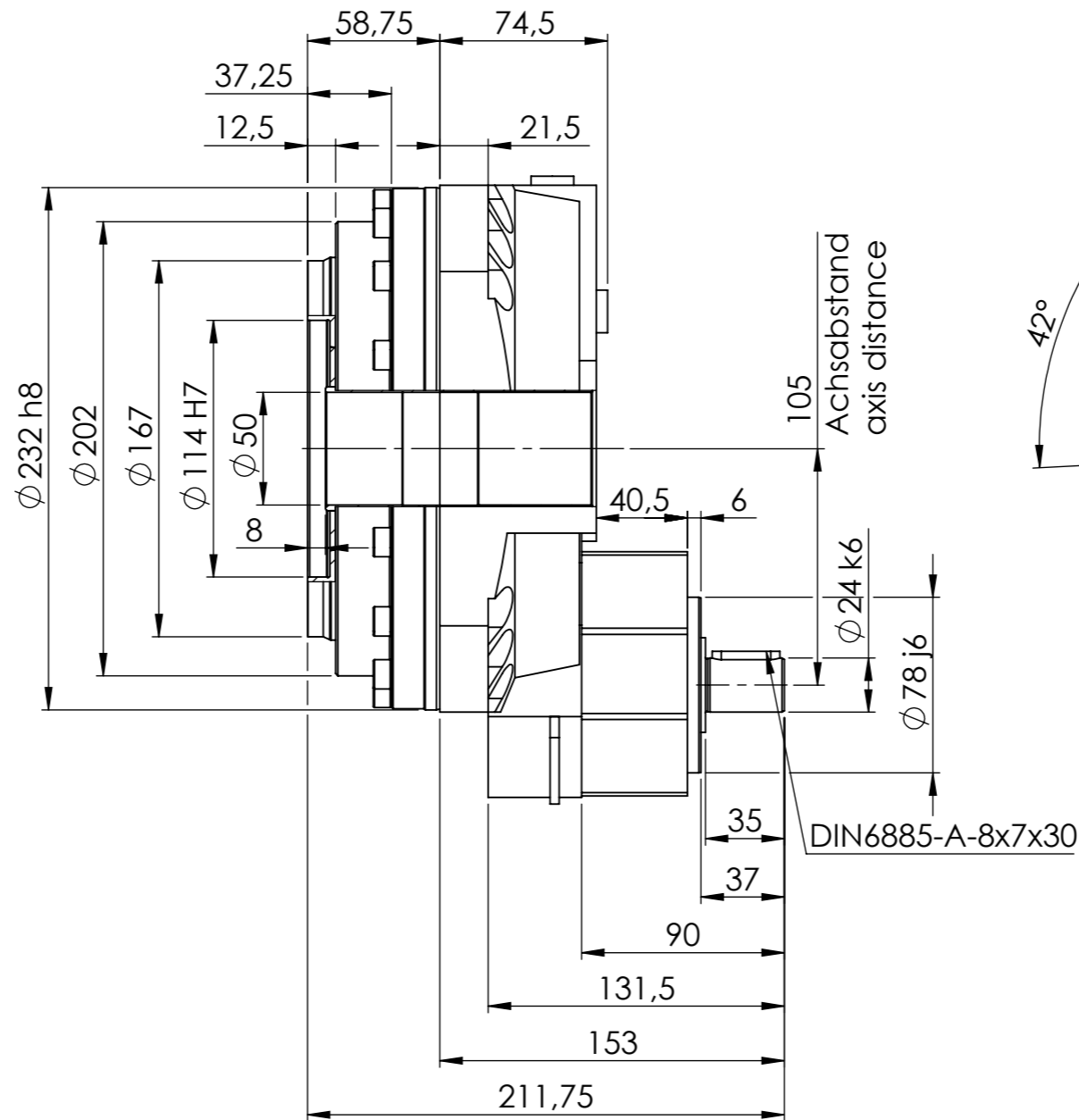
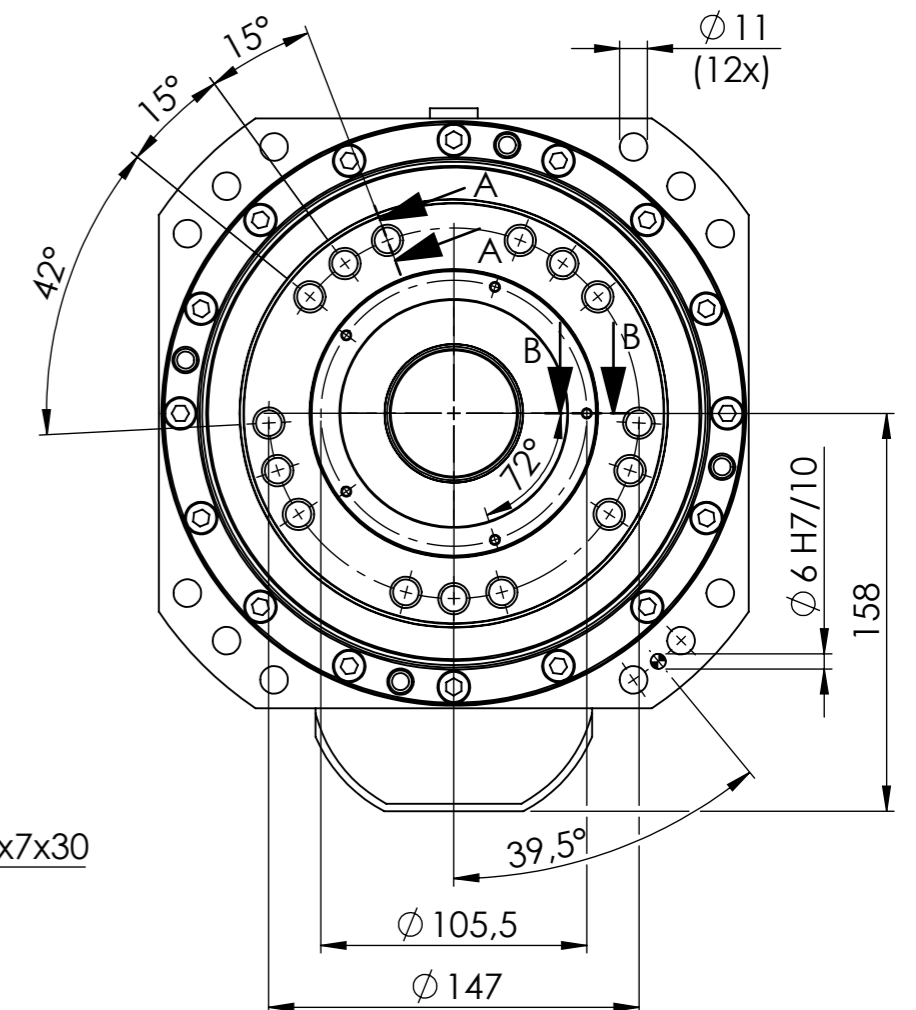

Varianten Variants PSC112H	
Nennübersetzung Nominal ratio	exakte Übersetzung Exact ratio
35,5	25422/725
45	26537/600
56	27429/500
71	28321/400
90	446/5
125	3122/25
131,5	-

				Datum	Name	Maßstab Scale	1:3	Teile-Nr. Part. No.	
			gez.	24.01.2020	AU	Werkstoff		Material	Masse
			gepr.	24.01.2020		Halzeug			
			Konstr.	24.01.2020	AU	Rohteil-Nr.			Mass
			Prod.T.	24.01.2020		Benennung			Title
			Qual.S.	24.01.2020		PSC112-H-B-XXX-2-XX-F-0			
			Mont.	24.01.2020		Zeichnungs-Nr.		Drwg.No.	Blatt-Page
									1 / 1
Idx	Änderungs-Nr.	Datum	Name	C A D					
Oberfläche-Surface DIN ISO 1302									
Allgemeintoleranzen General Tolerances									
Werkstückkanten DIN6784 Edges of working parts									
				Datei File	PSC112-H-B-XXX-2-XX-F-0			Ers.f. Repl.	Ers.d. Repl. by