

DETAIL D
MABSTAB 1.5 : 1

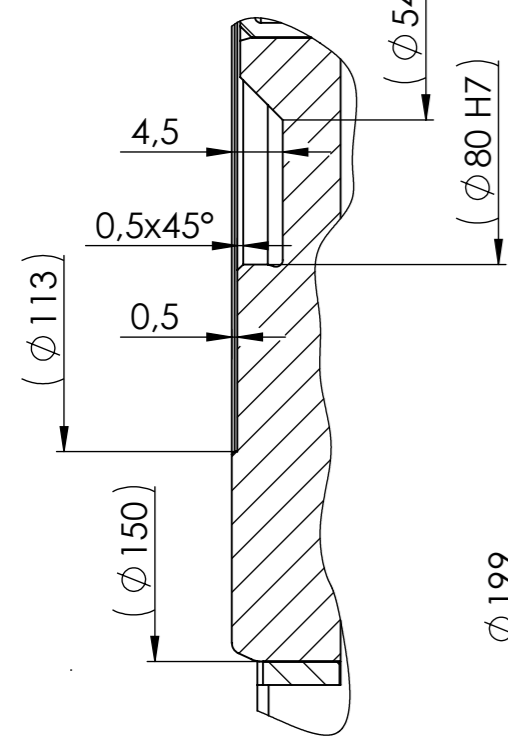

DETAIL B
MABSTAB 1 : 1

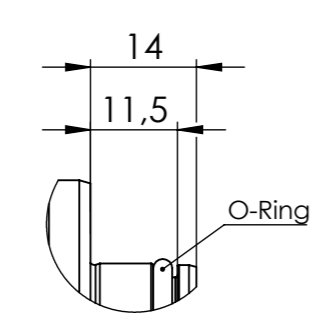

DETAIL C
MABSTAB 1 : 1

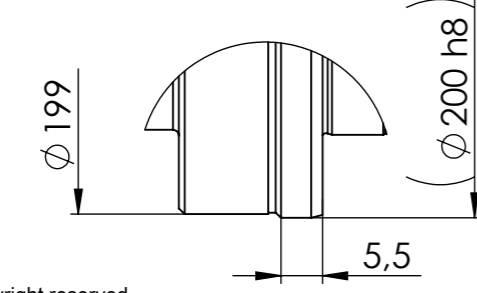

SCHNITT A-A
MABSTAB 1 : 1

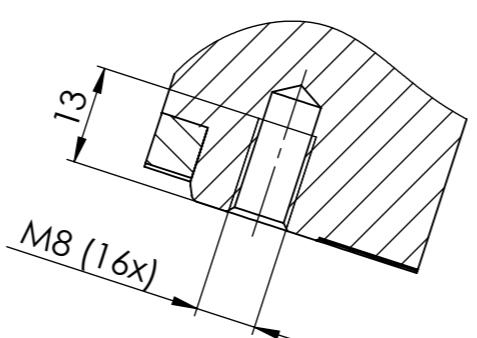

SCHNITT E-E
MABSTAB 1 : 1

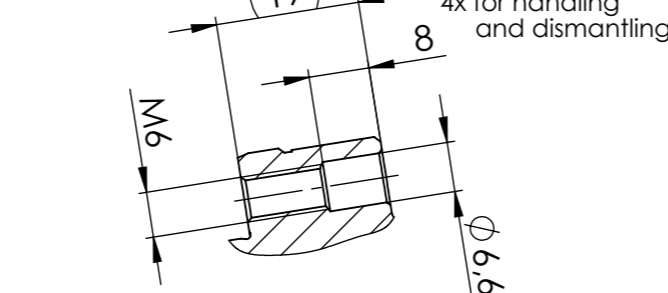

Schutzvermerk nach DIN34 beachten. Copyright reserved.

				Datum	Name	Maßstab	Teile-Nr.
				gez.	19.08.2019	AU	Scale
				gepr.	19.08.2019	FK	1:2
				Konstr.	06.04.2017	FK	Part. No.
				Prod.T.			Material
				Qual.S.			Masse
				Mont.			Mass
							Title
							PSC080-V-E-XXX-X-XX-F-0
							Einbausatz Vollwelle - KS3
							Zeichnungs-Nr.
							Drwg.No. Blatt-Page
							C0080-006-3A01
							1 / 1
							Ers.f.
							Ers.d.
							Repl.
							Repl. by