

DETAIL D
MAßSTAB 1.5 : 1

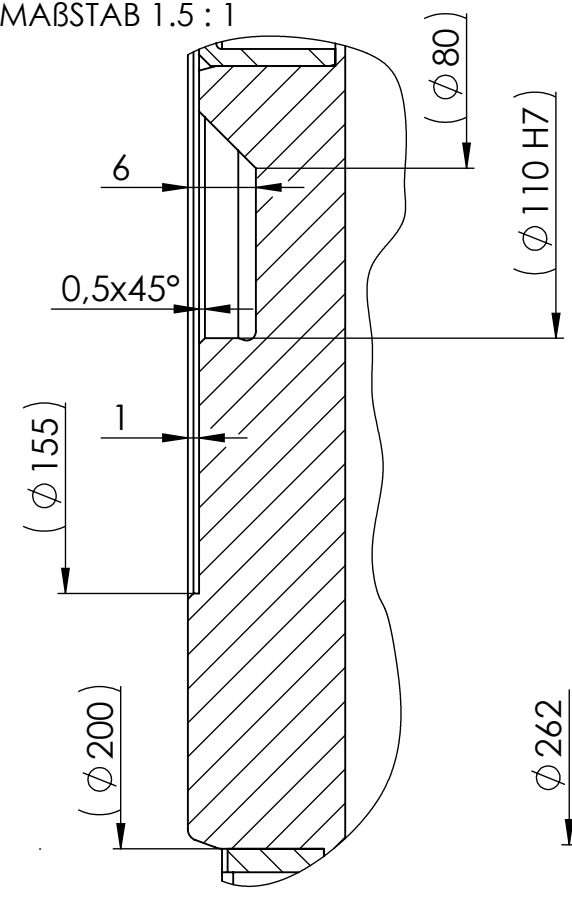

DETAIL B
MAßSTAB 1 : 1

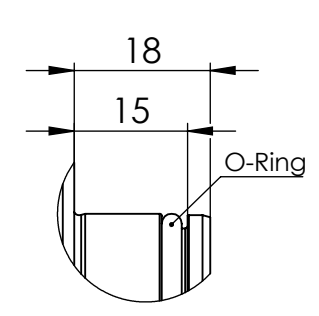

SCHNITT A-A
MAßSTAB 1 : 1

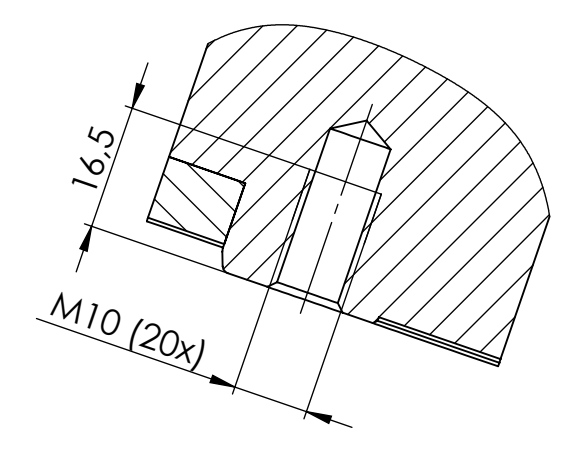

DETAIL C
MAßSTAB 1 : 1

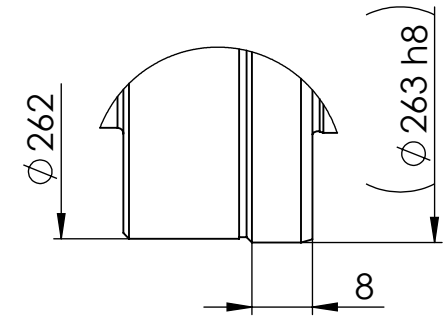

SCHNITT E-E
MAßSTAB 1 : 1

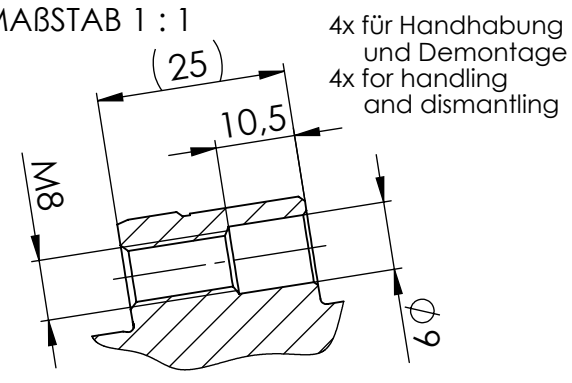

Schutzvermerk nach DIN34 beachten. Copyright reserved.

Idx	Änderungs-Nr.	Datum	Name	Datum	Name	Maßstab Scale	Teile-Nr. Part. No.
		gez.	19.08.2019	AU		1:3	
		gepr.	19.08.2019	FK		Werkstoff	Material
		Konstr.	10.04.2017	FK		Halbzeug	Masse
		Prod.T.				Rohteil-Nr.	Mass
		Qual.S.				Benennung	Title
		Mont.				PSC224-V-E-XXX-X-XX-F-0	
C A D						Einbausatz Vollwelle - KS3	
Oberfläche-Surface DIN ISO 1302 Allgemeintoleranzen General Tolerances						Zeichnungs-Nr.	Drwg.No./Blatt-Page
Werkstückkanten DIN6784 Edges of working parts						C0224-006-3A01	1 / 1
Datei File						Ers.f. Repl.	Ers.d. Repl. by
224V-KS3-SM-01							