

DETAIL D
MAßSTAB 1 : 1

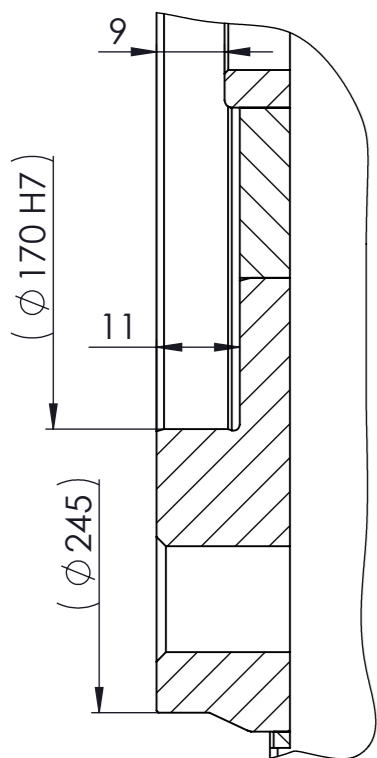

DETAIL B
MAßSTAB 1 : 1

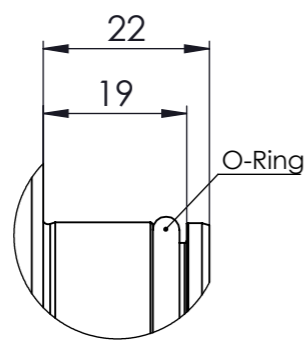

SCHNITT A-A
MAßSTAB 1 : 1

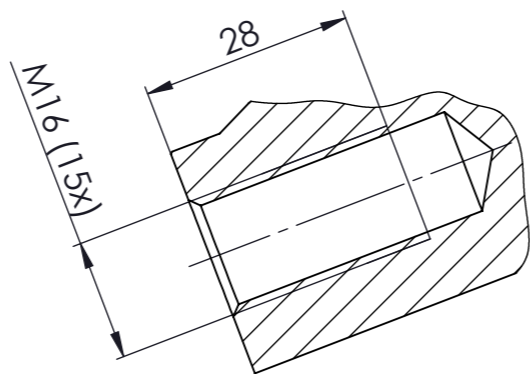

DETAIL C
MAßSTAB 1 : 1

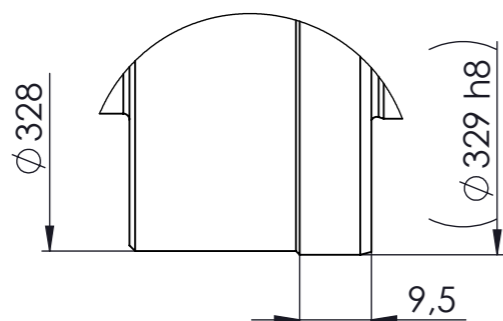

SCHNITT E-E
MAßSTAB 1 : 1

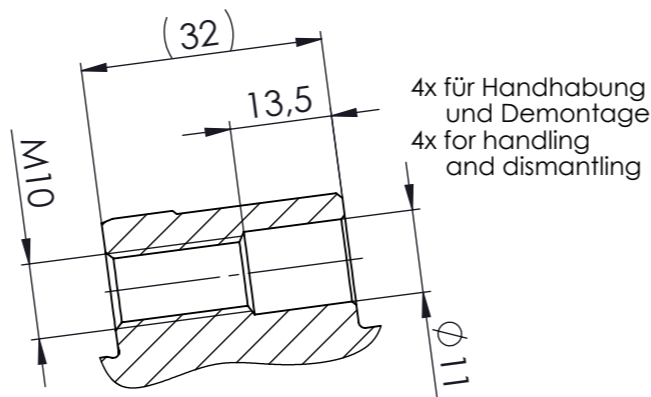

SCHNITT F-F
MAßSTAB 1 : 1

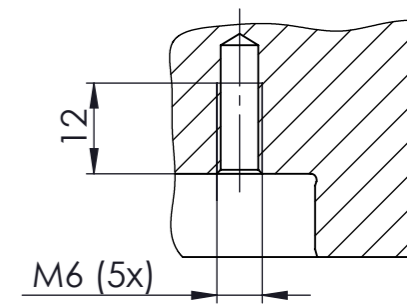

10x für Schutzhülse
10x for protective sleeve

Schutzvermerk nach DIN34 beachten. Copyright reserved.

				Datum	Name	Maßstab	Teile-Nr.
				gez.	20.08.2019	AU	Scale
				gepr.	20.08.2019	FK	1:4
				Konstr.	10.04.2017	FK	Part. No.
				Prod.T.			Material
				Qual.S.			Masse
				Mont.			Mass
							Title
							PSC400-H-E-XXX-X-XX-F-0
							Einbausatz Hohlwelle - KS3
							Zeichnungs-Nr.
							Drwg.No.
							Blatt-Page
							C0400-021-3A01
							1 / 1
							Ers.f.
							Ers.d.
							Repl.
							Repl. by