

DETAIL D
MABSTAB 5 : 4

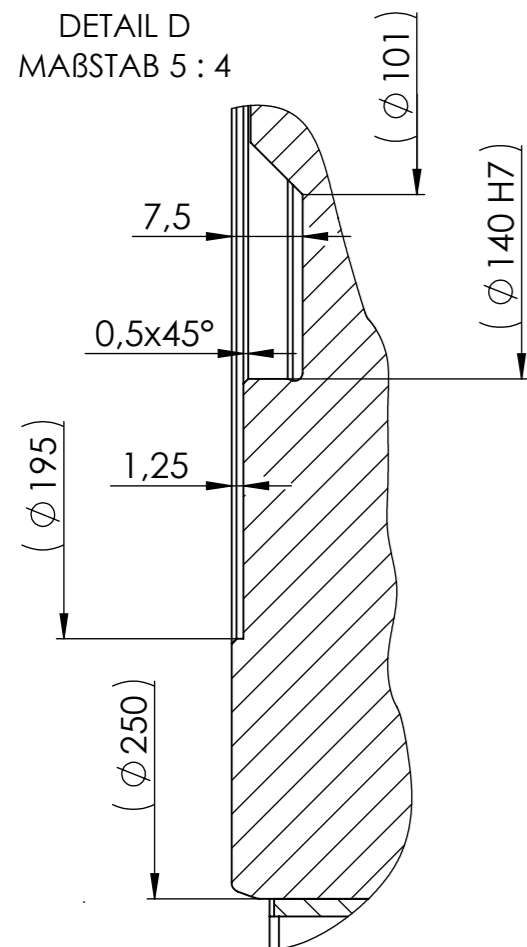

DETAIL B
MABSTAB 1 : 1.5

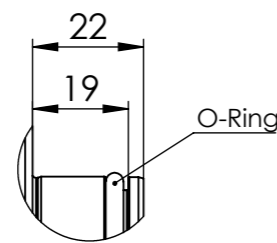

SCHNITT A-A
MABSTAB 1 : 1.5

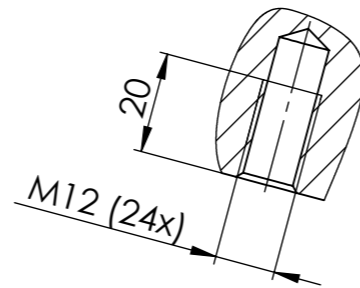

DETAIL C
MABSTAB 1 : 1.5

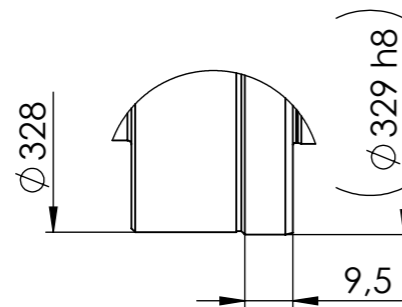

SCHNITT E-E
MABSTAB 1 : 1.5

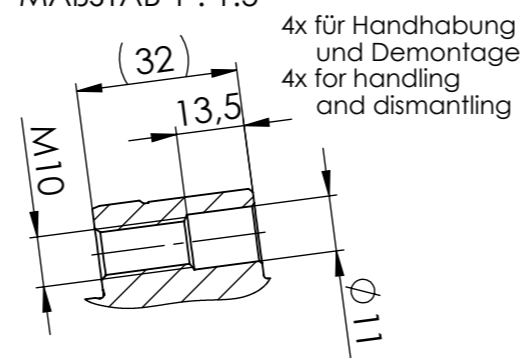

Schutzvermerk nach DIN34 beachten. Copyright reserved.

Idx	Änderungs-Nr.	Datum	Name	Datum	Name	Maßstab Scale	Teile-Nr. Part. No.
		gez.	19.08.2019	AU		1:4	
		gepr.	19.08.2019	FK		Werkstoff	Material
		Konstr.	10.04.2017	FK		Halbzeug	Masse
		Prod.T.				Rohteil-Nr.	Mass
		Qual.S.				Benennung	Title
		Mont.					
C A D				PSC400-V-E-XXX-X-XX-F-0			
Oberfläche-Surface DIN ISO 1302 Allgemeintoleranzen General Tolerances				Einbausatz Vollwelle - KS3			
Werkstückkanten DIN6784 Edges of working parts				Zeichnungs-Nr. Drwg.No./Blatt-Page			
Datei File				C0400-006-3A01			
Ers.f. Repl.				Ers.d. Repl. by			
Datei File				400V-KS3-SM-01			
Datei File				400V-KS3-SM-01			